



THE SETAUKET SPY

Benjamin Tallmadge District
Cub Roundtable News Letter



Volume 5, Number 2

September 2010 Cub Scout Roundtable

October 2010 Cub Scout Pack Meeting

RESPONSIBILITY

Tiger Cub, Wolf, Bear and Webelos Meetings 3 and 4

CORE VALUES

Cub Scout Roundtable Leaders' Guide

The core value highlighted this month is:

- ☆ **Responsibility:** Fulfilling our duty to God, country, other people, and ourselves. Cub Scouts will understand that everyone is responsible for fire prevention, and learn about the importance of keeping their promises.

Catalina Council

Responsibility:

- ☆ Responsibility is fulfilling our duty to take care of ourselves and others.
- ☆ Someone who is responsible will:
- ☆ Be dependable; do what you say you will do.
- ☆ Finish your homework.
- ☆ Take care of chores at home.
- ☆ Be helpful.
- ☆ Accept the consequences for your actions.
- ☆ Take care of your personal possessions.

CONNECTING CORE VALUES

Responsibility is always discussed in reference to something – to be responsible to or for something. For example, the boys will learn to be more responsible with money and resources (conservation) later in the year. Because the topic of responsibility is so broad, there are many directions leaders can go with it.

This month the boys are learning about responsibility through the achievements and activity pins they are working on. The Tigers are learning to take more responsibility for their health by making better food choices. The Wolves are also learning to take more responsibility for their health, and are tracking their progress on their health charts. The Bears are learning to ride a bicycle responsibly, and to take

care of their bicycles. The Webelos are gaining a deeper appreciation for nature, which will hopefully translate into greater environmental responsibility. And Arrow of Light Webelos are exercising (health & fitness responsibility) when they work on their Aquanaut.

PACK ADMINISTRATION HELPS

Youth Leadership In The Pack

Developing Leadership in Boys is what it is all about!! !!

The Denner and Assistant Denner
Scouter Jim, Bountiful, Utah

The **Denner** and Assistant Denner are the most important youth leadership positions in Cub Scouts. A Denner is a **Cub Scout** or **Webelos Scout** who is elected to be the temporary youth leader of his den. All Tiger Cub, Wolf, Bear, as well as Webelos Dens should elect a **Denner**. A den may elect a new **Denner** every few weeks, monthly, or other term. The Denner wears the gold double-strand [Denner shoulder cord No. 00368](#) over his left shoulder.



Importance

The Denner position provides many important benefits to the boy and to the den:

- ☆ Each boy serving as a Denner earns parts of various rank requirements. *Dens should rotate the*

position so that all members serve as a Denner at least once.

- ☆ Denners learn about leadership and responsibility first-hand.
- ☆ The Denner program helps give every boy a fair chance to lead.
- ☆ Each family shares equally in helping the den leader.
- ☆ The Denner position is preparing boys to be Patrol Leaders in Boy Scouts.
- ☆ Scouts and parents who are allowed to help are more like to stay in Scouts.
- ☆ Denners are recognized by being allowed to wear the Denner's [gold cords](#).

Rotation

Certain ranks require that every boy serve as Denner. Also, the Denner leads the flag and opening ceremony as required for various ranks. However a popular boy who is re-elected may deny others the opportunity to learn and advance. For this reason, the Den Leader may decide that boys who have already served as Denner may not be elected again until every other boy has had a turn. Alternately, a single Denner election may be held at the beginning of the year to determine the Denner schedule for the year, with new den leaders rotating monthly or of every few weeks.

In the lower cub ranks, Denner elections may not be the best approach, as you commonly end up with each boy voting for themselves, or boys getting very upset when they do not win the election. Some possible approaches are to appoint them in alphabetical order, or by drawing names from a hat.

By Webelos age, the boys should be able to handle elections, and this will be a good lead-in for [Patrol Leader](#) elections within Boy Scouts.

Responsibilities

The Denner (typically along with his parent or adult partner) have many important duties as assigned by the Tiger Cub Den Leader, Cub Scout Den Leader or Webelos Den Leader that may include:

- ☆ Help with [den meeting](#) setup.
- ☆ Lead the opening ceremony (flag, oath, law).
- ☆ Take the Den Attendance and dues meetings.
- ☆ Help with the meeting activities.
- ☆ Provide simple refreshments such as cookies and cups of juice.

- ☆ Lead the closing ceremony.
- ☆ Help with [den meeting](#) cleanup.
- ☆ Help with other responsibilities as assigned by the Den Leader.

Assistant Denner

The Assistant Denner assists the Denner at den meetings and fills in for the Denner when the Denner is not available. The Den Leader may establish a practice of the Assistant Denner becoming the Denner in the next term. This way the Assistant Denner can watch and learn from the Denner so that he will be ready for the next term. Using this approach, the Assistant Denner is elected each month to become the Denner the next month.

The Assistant Denner wears the gold single-strand [Assistant Denner shoulder cord No. 00385](#) over his left shoulder.

BAITING HALLOWEEN

October 23 10am - 4pm (Rain or Shine)
Hosted by Benjamin Tallmadge

\$13 for children 5-18 and \$4 for accompanying adults.

Admission includes Hay Ride, Pumpkin Patch with Painting Pumpkins, games and a lot of other great activities.

Come in Costume and you may get a Prize!



For more information, contact: Kathy Westrich at 631-698-6040
Register with the form on www.btdistrict.org/id20.htm available at the events page.

SPECIAL OPPORTUNITIES

Good Manners

www.usscouts.org



This subject was added in 2009. This is certainly one area where a Cub Scout of any age can be responsible. That is he is always the only one responsible for his behavior!!

Belt Loop Requirements

Tiger Cubs, Cub Scouts, and Webelos Scouts may complete requirements in a family, den, pack, school, or community environment. Tiger Cubs must work with their parents or adult partners. Parents and partners do not earn loops or pins.

Complete these three requirements:

1. Make a poster that lists five good manners that you want to practice. Share your poster with your den or family.
2. Introduce two people correctly and politely. Be sure that one of them is an adult.
3. Write a thank-you note to someone who has given you something or done something nice for you.

Academics Pin



Earn the Good Manners belt loop, and complete five of the following requirements:

- ☆ Meet one new person, shake hands properly, and introduce yourself. Extend your hand, grip the person's hand firmly, and gently shake hands.
- ☆ Talk with your family about polite language. Include "please," "you're welcome," "excuse me," "yes, sir," "no, ma'am," and so on in your talk.
- ☆ Explain to your den or family how good manners can help you now and as you get older. Copy the actions of someone you know who has good manners.
- ☆ Go over table manners with your family. Eat a meal together where the table is set correctly and everyone uses good table manners.
- ☆ With an adult, discuss what foods are proper to eat with your fingers. Practice eating some of these foods the right way.
- ☆ In your den or with your family, practice using good phone manners.
- ☆ Explain how treating things that belong to other people with respect is a part of having

good manners. Show three examples of how you can show respect for others.

- ☆ Talk with your friends or family members about following the rules and having good sportsmanship when playing games. Then play a game with your friends or family members. After playing the game, tell how you showed good manners.
- ☆ With your family or den, list five rules to remember in being polite and respectful when in a public place. Go to the public place and practice the rules. Explain how the rules helped you to have good manners.
- ☆ Demonstrate the proper outfit to wear at school, at play, and at a social event.

CONNECTING CORE VALUES WITH OUTDOOR ACTIVITIES

Catalina Council

- ☆ Pair up with a buddy and be **responsible** for him throughout the hike. Stay on the trail. Leave no trace.
- ☆ Each boy brings a specific nature time to the meeting demonstrating he is **responsible** to remember his assignment. Also, each boy is **responsible** in bringing items that are allowed and not disturbing any nature preserve or ecology site.
- ☆ Mow the grass for elderly neighbor for a specified duration. Make a duty roster. Each Scout is **responsible** to do his part.
- ☆ Each boy is **responsible** to bring certain piece of equipment to play a game (bat, ball, glove for baseball).
- ☆ Do a den ceremony where each boy is **responsible** to act or say his part. Adults model **responsibility** by having advancement.
- ☆ Boys could help set up and clean up campfire area. They are **responsible** to make sure the fire is completely out.
- ☆ Visit a local bank or credit union and talk about how these institutions are **responsible** for safeguarding other people's money.
- ☆ Have boys help to plan one of the overnighter activities. Be sure to evaluate afterwards to discuss how success is related to **responsible** behavior.

BT District Fall News

The District "Take Your Camera to Camp" Photo Contest!

Yes, we have something never tried before in our District. Submit your best camping photos between May 15 and November 1.

For more info, contact Frank Bailey at this RT. [Email](#) is good too ;)

Youth Protection Training

Benjamin Tallmadge District has responded to the National Directive that all leaders be Youth Protection trained or the leader will be dropped from the unit's Charter. **It has been discussed that Charter Organization Reps need to have this training or risk getting dropped.**

We recommend that if online is not an option, please make every effort to attend one of the next two Roundtables. Ken Tinsley, our new District Training Chair, is arranging for Youth Protection Training. Please note the following Roundtable Dates:

October 14	Youth Protection Training Available at Roundtable
November 18	Youth Protection Training Available at Roundtable

Don't be caught with an expired Youth Protection Certificate. Come to Roundtable and get your certification. Bring others from your unit as well.

Centennial Camporee Cub Day October 16



Have you taken advantage of the discount offered for day trippers. If you pay before October 8, it's only \$10. After that \$15.00. So save the \$5 and register now.

If you want to know why should you come, check our feature article from August's *Setauket Spy* edition. Ask any of the district people at this September's RT. Here's an excerpt:

Brian recently sat down with me to relate all the different activities that should keep a Cub Scout busy that day. Brian has been attending all the meetings and I can attest that he became a valuable member of the Cub Scout Activities team, together with Donna Dunn and Ida Brownley. The Cub Scout Activities team has representatives from nearly all the districts in the Council. Together they came up with some great activities.

Be sure to speak to any of the District people if there are any concerns. Stay all day, there is a concession stand and after Religious Services, a GREAT SHOW.

An Invitation to all Pack Leaders....

Since January's issue of Setauket Spy, we have highlighted several OUT-STANDING packs. I know this district is chock full of great Packs, I've only touched the tip of the proverbial iceberg. Are you a great PACK but nobody knows about you?? This is your chance. Contact me (Sylvia Murdolo, Editor) by email: encourager@optonline.net; house phone: 631-476-9243 or cell: 631-327-6486 and tell me about yourselves. Don't think you can write?? (Ridiculous :) However, I can help you in that department too! Let us know about your normal activities and what makes you special.

Yours in Scouting,
Sylvia



WEBELOS WEBELOS-to-Scout Transition

Westchester-Putnam Council

One of the most important, but perhaps least discussed responsibility of both a first year and second year Webelos adult leader is to include activities in the program to prepare WEBELOS for the eventual transition to Boy Scouts.

Our aim should be to make the transition an easy one for the boys. Webelos leaders and parents share in this responsibility.

- Start early
- Visit Troop meetings
- Organize joint den/troop campouts
- Visit troop activities
- Discuss options with adults and boys
- Encourage completion of the Arrow of Light
- Promote the move to Boy Scouts to both Webelos and parents.

Leaders of a fifth grade Webelos den should plan out transition activities during the six months that the boys are earning their Arrow of Light. In fact, be-

sides the activity badges, requirements to earn the Arrow of Light include preparation to join a Boy Scout troop, troop visit, outdoor activity, an overnight campout or day hike and a scoutmaster conference.

The following is a sample checklist for activities to support transition to Boy Scouts:

September

- Have your den select a Scout patrol name, get patrol patches to wear, make a patrol flag, and elect a Patrol Leader. Check the Scout Handbook for ideas.
- Provide parents with an outline for their role in the transition.

October

- Ask your Roundtable Commissioner to sponsor an information sheet exchange to allow den leaders to provide contact information to Boy Scout leaders. The sheets may be given out at the October Roundtable and returned to the November Roundtable. This is very important so that Troops can send you information regarding open house opportunities and invite your den to Troop meetings, Courts of Honor, and outdoor activities.

(Note: make sure that activities are age appropriate <http://www.scouting.org/filestore/pdf/ageguides.pdf> and outdoor program guidelines <http://www.scouting.org/filestore/pdf/510-631.pdf> for Webelos JT)

- Leaders should begin visiting local Troops in your area personally and meet their Scoutmasters. A key factor in a successful Webelos-to Scout transition is a working partnership between the pack and the Boy Scout troop.

November

- Take your Webelos and their parents to visit Troop meetings for at least 2 different Troops.
- Encourage your Webelos to make a final decision on joining a Troop. Make sure that they understand that they need to make their choice by January. Scoutmasters can be attendance at Blue & Gold in February

December

- Assist the Cubmaster in planning a top-notch, personalized graduation for the Blue & Gold Banquet in February.

January

- Assist your Webelos in the completion of their Arrow of Light requirements.

February

- Graduate your Webelos into Boy Scouts.

Have them complete a Scout application and register with a Troop. New Scouts should have a Scout Handbook by this time (*a great present from the Pack to graduating WEBELOS.*)

March

- Be sure that new Scouts have a schedule and begin attending Troop meetings in their new Troop(s). Encourage parents to get involved as Patrol advisors or in the Troop Committee.
- Talk to the Scoutmaster of your Troop and volunteer to work with the new Scouts as a New Scout Patrol advisor (or better yet an Assistant Scoutmaster). This will help boys become comfortable in the new Troop.
- Follow up with any of your Webelos as to why they did not join a Troop.

For Webelos Scout's Parents

As mentioned, parents have an important role in a successful WEBELOS-to-Scout transition. As soon as your den meetings begin in September, provide the parents with a document which sets out their roles. The following sample is used by some dens to guide their parents and should be adapted to meet your particular situation:

September

- Meet with your Webelos Leader regularly to discuss the Webelos-to-Scout transition process. Make sure you understand when things will happen so that you can help prepare your Webelos. Volunteer to assist in any way.
- Refer to the Webelos-to-Scout transition often and tell your Webelos how proud you are that

Special District Invitations to Webelos Leaders
Two Events that are especially geared for you and your Webelos Scouts!!

First Event: Webelos Outdoor Leader Skills (WOLS)...Join Training Chair [Ken Tinsley](#) & Team for a whole overnight experience. It has been a few years but the campfire can't be beat. You will walk away with a deep understanding of the need for OUTING in SCOUTING.

Dates: Saturday, October 9 and Sunday, October 10.
Place: Baiting Hollow Scout Camp.

Price \$25 per person and includes fees, materials and food. See flyer on our district event page. With the right training you can enjoy the weekend because Ken & Company will teach you "how to have the boys do all the work so they can learn and we get a break for the weekend!" And then....

he will soon become a Boy Scout. Use positive terms that convey an expectation that your son will continue in Scouting.

- Assist your son in the completion of his Arrow of Light requirements.

October

- Provide your Webelos leader with the birth date of your son as well as your latest contact information. Your Webelos leader will need this information to help local Troops prepare for Webelos recruiting.
- Talk with your Webelos leader about the Troop visits that happen in November or December.
- Find out about the local Boy Scout Troops in our area using a Troop Directory available from your Webelos leader or by visiting an online directory provided by your local council. Make sure that the Troops you want to visit are included by the WEBELOS leader or visit them separately.

November

- Encourage your son to make a final decision on joining a Troop. Make sure that they understand that they need to have their choice completed by January so that Scoutmasters can be attendance at Blue & Gold in February.

December

- Consider providing your son with a Boy Scout Handbook during the holiday season. Encourage him to read the handbook and find out what Boy Scouts do.

February

- Graduate your son into Boy Scouts. Have them complete a Scout application and register with a Troop. New Scouts should have a Scout Handbook by this time.

March

- Make sure that your new Scout has a Troop schedule and is attending Troop meetings. Volunteer your time as a Patrol advisor, Assistant Scoutmaster or in the Troop Committee.
- Pay attention to your son's involvement and his level of enthusiasm for Scouting. Most boys fit into a particular Troop seamlessly but others do not. If you believe that your son would do better in a different Troop, use the Troop directory to begin your own Troop visits to other Troops. Once your registration dues are paid you can transfer to another Troop for \$1 just by completing another Boy Scout application. It's that easy.
- One issue that is not addressed soon enough for me is SUMMER CAMP. Find out if the Troop has a program for the summer and plan on sending your youngster. Statistically, the boy that attends Boy Scout camp stays in Boy Scouts.

And part two...NOW THAT YOU ATTENDED WOLS, now you can put it into action! We cordially invite your Webelos Den Leaders and the entire Den to BT Webelos Woods. We have a lot of troops who want to meet you. Contact Ida Brownley for the event at her cell phone: 516-509-8954 or by email: IdaBrownley@aol.com.

MARK YOUR CALENDAR

September

- 16 Roundtable, Back at Norwood Ave ES
- & 25 *POPCORN*: Show N Sell Distribution

October

- 2 TRAINING: Cub Scout Leader Specific at BHSC
- 9-10 Webelos Leader Outdoor TRAINING
- 14 Roundtable
- 16 *Cub Scout Day at the Centennial Camporee* (See pg 4)
- 23 *Baiting Halloween* (See P. 2)
- 25-30 *POPCORN*: Week to return Show N Sell Product at Council Service Center

November

- 1 *POPCORN*: Take Order & Prizes Due
- 5-7 Webelos Woods BHSC
- 12 & 13 *POPCORN*: Take Order Distribution
- 13 TRAINING: Cub Scout Leader Specific
- 18 Roundtable
- 28 10 Commandment Hike

December, 2010

- 3 *POPCORN*: Payment Due!
- 4 Den Leader TRAINING
- 9 Roundtable

January, 2011

- 13 Roundtable
- 22 University of Scouting

February

- 6 Scout Sunday
- 10 Roundtable
- 12 Scout Sabbath
- 27 JCOS' Awards Breakfast

March

- 10 Roundtable
- 12 BALOO TRAINING
- 19 Scouting for Food
- 23 TRAINING: Cub Scout Leader Specific

April

- 2 Cub Fun
- 14 Roundtable
- 30 Cub for Cub

May

- 7 AM: Work Day at BHSC
PM: District Dinner
- 12 Roundtable
- 20 JCOS Conclave at BHSC
- 27-30 **Family Camping at BHSC**
- 28 Memorial Day Flag Placement

June

- 4 Flag Retrieval Day
- 9 Roundtable at BHSC

July

- 1-5 **Family Camp**
- 5-9 Cub Resident Camp

August

- 14-18 Cub Resident Camp
- 18 Roundtable
- 9/2-5 **Family Camp**

Disclaimer: This is a partial list. Please consult the BT District Website and the Council Website for any changes.

GATHERING ACTIVITIES

Responsibility Activities

Dot-to-Dot Fire Engine
Golden Empire Council

Can you find the message in this Dot-to-Dot? It's something you should know and be ready to use responsibly!

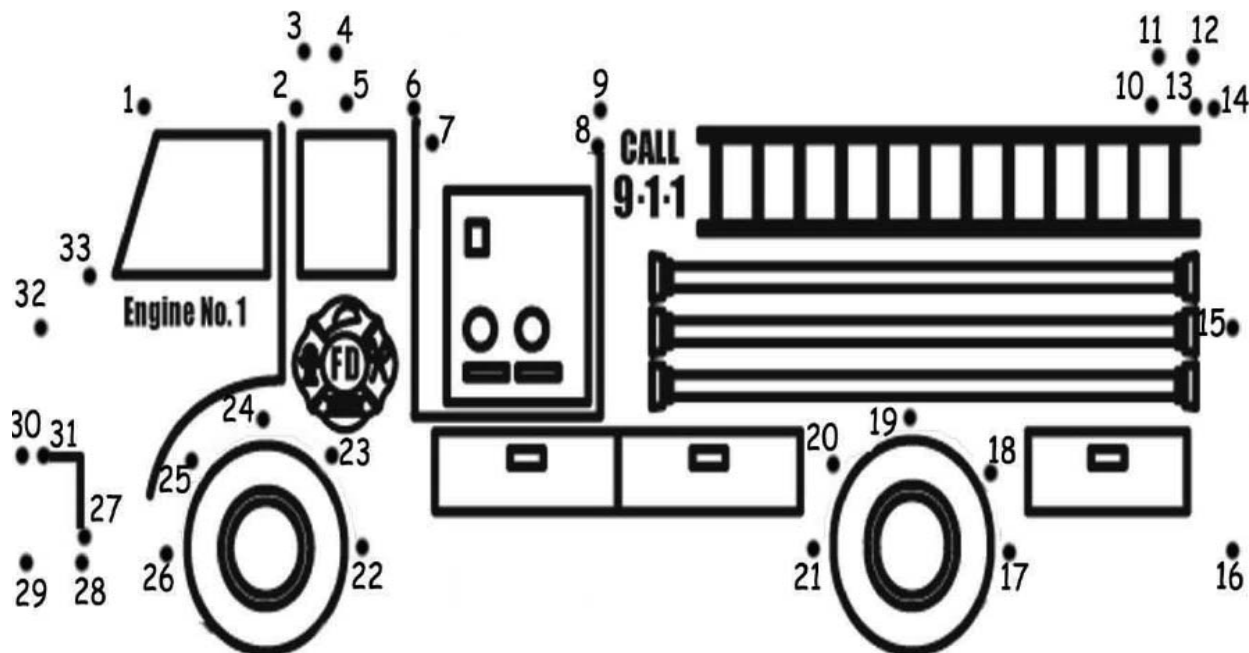

Webelos: Answer the following questions and share the answers with your younger brother Cub Scouts.

1. When should we call 9-1-1? What type of information should we have ready to tell the 9-1-1 Operator?
2. Who handles our 9-1-1 phone calls for medical help? Where are their offices?
3. True or false: All 9-1-1 phone calls are handled by one center.
4. If it isn't a real emergency, what Suffolk County number should we call for help?
5. Do a SKIT for Pack night about being responsible with 9-1-1.

N
S
a
y
Corner

Special September

Source: <http://www.brownielocks.com>

National Preparedness
Month

Turn Off Your TV Week,
Sept. 19-25 ([Link](#))

National Good
Neighbor Day, Sept.
26

Sea Cadet Month

National Keep Kids Crea-
tive Week,
Sept. 26-10/2

Family Day - A Day to
Eat Dinner with your
Kids, Sept 27 ([Link](#))